

DENTAL



AWD655

Instruments Washer
Disinfector

www.at-os.com

Your Health, our Technology



External Lab Certificate of Type Test validation, according to the Standard EN ISO 15883-1/2 and 5



Plumbing system designed to isolate the potable water pipeline system (water gap) as prescribed by European Standard EN 1717



A smart line for the disinfection of dental instruments, to wash and disinfect instruments safely and impeccably.

The machines guarantee perfect results thanks to the use of the highest technologies and they are able to meet all the requirements of the dental sector, thanks to the wide range of models offered.

To guarantee always perfect washes and ensure the best quality of the result, AT-OS offers a line of state-of-the-art washer disinfectors with pre-set and specific programs for each type of dental instruments and the possibility of ad hoc customized programs to meet every type of need. The washing programs are the result of years of study and experience in the field of dentistry and orthodontic to obtain repeatable and validable results.

Each function is adjusted via an user-friendly color graphic display, in order to facilitate the use of the machine by the user. Thanks to the latest generation electronic components, each washing cycle parameter is constantly checked and monitored.

Instruments Washer Disinfectors with high reliability, for the benefit of users and patients.

AT-OS instruments washer disinfectors have been developed to meet hygiene standards ISO Standard EN-ISO 15883-1/2 and 5.



Excellent results



Up to 265 liters of volume



Color graphic display



Energy saving



Perfect disinfection



High reliability

AWD655 line



AWD655-2
Glass door and
with drying



AWD655-2XE
Stainless steel door
and without drying



AWD655-2H
Glass door and
with drying

AWD655-8X
Stainless steel door
and with drying



AWD655-8XE
Stainless steel door
and without drying



AWD655-8
Glass door and
with drying

AWD655-8XL
Stainless steel door
and with drying

AWD655-8XEL
Stainless steel door
and without drying



AVAILABLE
MODEL
WITH
BOILER

AWD655-8L
Glass door and
with drying

AVAILABLE
MODELS
WITH 1 or 2
BOILERS

AVAILABLE
MODELS
WITH 1 or 2
BOILERS

AWD655-10D
Double glass door
and with drying

AWD655-10
Glass door and
with drying





Chemical-resistant double glass

The door is made of two layers of tempered glass, resistant to chemicals, even the most aggressive ones. It allows to see inside the wash chamber during operation.



Stainless steel design

The wash chamber is made of stainless steel AISI 316L (EN 1.4404) while the chassis and external panels are made of stainless steel AISI 304 (EN 1.4301). They are shockproof and long-lasting. Scotch Brite surface finish makes cleaning easier.



Ergonomic handle

Thanks to the ergonomic handle, on models equipped with manual door, the door opening and closing functions are made easy without efforts.



Support for an easy access

On request, AWD655-2H and AWD655-8 (and variants) can be equipped with a stainless steel support, under the machine, that provide an ergonomic height when the machine is not installed under the counter, making the access to the machine easier for the operator. The support is also useful for storing chemicals.



Door locking and security system

The machines are equipped with an automatic door locking system which ensure a safety door block. For the safety of the operators, the machine does not allow the door to be unlocked during the wash cycle or in the presence of high temperatures. An extra sensor guarantee that, even if in presence of a malfunction of the machine, the water pump will be switched off with the unlock of the door.



Printer

On request, the machines can be equipped with a printer that prints the receipt log of the running program.



Touch-pad keyboard with graphic display

The touch control panel consists of 8 backlit keys and a 3.5" LCD display. The flat display with colour graphics shows all cycle parameters, alarm messages, measured temperatures of the two temperature probes positioned in the wash chamber, drying temperatures and A_0 value. The AWD655-10 with double door is equipped with screen monitor on both sides.



Alarm-check system

This system helps the operator to understand why an alarm has occurred before consulting the user manual. A text appears on the display with the number, the image of the alarm and the text explaining the possible causes of it.



Customizable programs

The machines are supplied with a set of standard programs, variable according to the model, and with the addition of customizable programs, up to a maximum of 40 total programs.



Double door system

The AWD655-10D is equipped with two interlocked doors: one for loading the dirty trolleys with the instruments to be washed (dirty area) and the other positioned at the rear for unloading the clean trolleys with the disinfected instruments (clean area). The machine does not allow the unlocking of the two doors at the same time. The door of the basket in the unloading area is unlocked only if a cycle is successfully completed.



Wash chamber LED light

On request, the machines can be equipped with a LED light positioned inside the wash chamber, with low energy consumption, for a better visibility during the wash cycle and during loading and unloading of the basket or trolley. For AWD655-2 and AWD655-8 (and variants), the LED may vary in color depending on machine status. In the event of an alarm, the wash chamber lights red; when the cycle is successfully completed, the wash chamber lights green.



Reliable washing

Thanks to a dedicated pressure switch that monitors in real time the water pressure of the washing circuit, all the washing parameters will be always perfect. An alarm message on the display will indicate if there's a pressure lost during the cycle, causing a cycle stop.



Microcontroller

The machines are equipped with a microcontroller that constantly monitors its operation. It's provided with an internal flash memory that allows the machine to store all the information regarding: cycle params, alarms and log history. An internal watchdog monitor the microcontroller and block the device in case of a malfunction.



Boiler for Speed Cycle

The models with boilers help to speed up the water heating times and to save water. The first boiler is filled with deionized water maintained at a pre-set temperature thanks to its internal heating element, it helps to reduce the electricity consumption and to increase system efficiency; the second boiler allows to reduce hot water loading times and save water by reusing deionized water at the end of the phase.



Water softener system

On request, the machines can be equipped with a system that makes it possible to soften the cold and hot water (depending on the model) entering the wash chamber, so as to reduce the formation of limestone in the hydraulic circuit of the machine. The machine automatically regenerates the resins based on the water hardness set at the time of installation.



Steam condenser system

The machines are equipped with an effective steam condenser system that acts to reduce the steam during the disinfection and drying phases.



Spray arm monitor

On request, the machines can be equipped with the spray arm monitor system. If the spray arm monitor is enabled, it checks the correct rotation of the spray arm. An alarm message on the display will indicate a problem during the cycle.



Conductivity probe

On request, the machines can be equipped with a conductivity probe that checks the water purity level at the end of rinsing, before disinfection. The machine repeats the rinse cycle again to remove any residue if the conductivity probe detects a water purity level, expressed in $\mu\text{S}/\text{cm}$, higher than the preset one.



(E.T.S.) Empty Total System

On request, AWD655-10 (and variants) can be equipped with the E.T.S. system which, at the end of each cycle, automatically discharges the residual water from the pump, water storage tank and pipes, to ensure complete cleaning inside the machine.



Automatic washing trolley recognition

On request, AWD655-10 (and variants) can be enabled to understand when a trolley is inserted: it is not possible to start a program if there is no trolley inside the wash chamber. The application recognizes which type of trolley is inserted and suggests to the user which program to start. However, it remains possible to enable or disable programs that are not recommended for this type of trolley.





Drying with HEPA H14 filter

During the drying phase the forced air, pushed by a blower, is introduced into the washing chamber, passing through an electric heater. The air then comes out of the jets of the spray arms to ensure a warm uniform air distribution. The HEPA H14 filter allows to block the fine dust present in the air with an efficiency of 99.995%. Furthermore, in order not to damage the filter, a pre-filter is placed in front of it to block the larger particles.



Models without drying system

AWD655-2XE, AWD655-8XE and AWD655-8XEL are without drying system: at the cycle end the machine automatically opens the door, partially, to dry the instruments with a natural air recirculation, saving on consumption. Read the user manual for more info and details.



Filter cleaning sensor

A dedicated vacuum switch monitors the HEPA H14 filter clogging. An alarm message on the display will indicate that the filter is clogged, causing a cycle stop.



External heating system

In the AWD655-2 (and variants) model the water heating elements are positioned outside the wash chamber: this solution avoid water and chemicals to be in contact with the electrical active components of the heaters.



Coil for facility steam

On request AWD655-10 and AWD655-10D can be equipped with a coil at the bottom of the chamber carrying facility steam. This speeds up the times required to heat water. It is also possible to use only the coil, excluding the heating elements.



Hybrid heating system: electric + steam

On request, AWD655-10 (and variants) can be equipped with a hybrid heating system: the water is heated both by the heating elements inside the tank and by the network steam. In this way it is possible to reduce program times and electricity consumption.



Detergent storage compartment

In the AWD655-2 models, the access to the detergent storage compartment is prevented to unauthorized persons by a locked door. In addition, in the counter top model, cleaning operations are facilitated by a fully removable basket. On the AWD655-8 models with side panel, the detergent storage compartment is located in the side panel with a handle to allow access to it. In the AWD655-10 models the tanks are located in a compartment with locked door at the bottom of the machine.



Chemical dosing control

The dosing system for chemical products is controlled by a flowmeter. If the flowmeter doesn't perceive the passage of the liquid, after a few seconds the display will show an alarm that warns the operator of the non-dispensing of the liquid in the wash chamber, causing a cycle stop.



Chemical products level sensor

The machines are equipped with a sensor placed in the suction probe of chemical products, which warn the user if the liquid is running out through a warning that appears on the LCD display.



RS232 port connection



USB port

The two USB ports:

- USB 2 type A for PC USB: allows to connect the machine to a PC for programming;
- USB 2 type B for flash drive: allows to download the history of programs executed and alarms, or for update the firmware and dataset.

Only for
AWD655-2
AWD655-8
and variants



Washer RePortal

Software to connect to the machine to manage the user PIN and download, via USB PenDrive, the cycles ran, that are saved on a special database, moreover it is possible to generate the cycle reports in PDF format and export them in CSV format.



User pin management

Manage a secure access to the programs by the users. An user name and password protection level limit the access to the device only to authorized personnel.

Want to know
more about
Washer RePortal?

Contact us for
the brochure!

info@at-os.com



7 DAYS
FREE
TRIAL

POWERED BY **AT-OS**

**Washer
RePortal**

THE BEST SOFTWARE
TO CONNECT TO
YOUR AT-OS MACHINE

65 LT

AWD655-2 | AWD655-2XE AWD655-2H

Counter top and under the counter

Machines equipped with a manual opening and closing door made in double tempered glass or stainless steel, perfect for dental clinics and ward departments. The water heating elements, placed outside the wash chamber, ensure a longer life of the system. They are equipped with a system that filter, electrically heat and force, with a powerful blower, the air in the wash chamber and inside the hollow instruments, to obtain an excellent drying result (not available for the model without drying system). A large variety of accessories completes these machines, suitable for washing and disinfecting all types of dental instruments, handpieces and accessories.



AWD655-2

Glass door and with drying



AWD655-2XE

Stainless steel door and without drying



AWD655-2H

Glass door and with drying



Wash chamber with spray arms



Multi filters in the wash chamber



Chemical tanks



External printer connected by cable



HEPA H14 filter and prefilter

■ Technical features

	AWD655-2	AWD655-2XE	AWD655-2H
Model code	112002029	112002039	112002030
Wash chamber dimensions (WxDxH)	428x415x370 mm (16.9"x16.3"x14.6")	428x415x370 mm (16.9"x16.3"x14.6")	428x415x370 mm (16.9"x16.3"x14.6")
Wash chamber volume	65 lt (17 US gal)	65 lt (17 US gal)	65 lt (17 US gal)
Wash chamber material	AISI 316L (EN 1.4404)	AISI 316L (EN 1.4404)	AISI 316L (EN 1.4404)
Indicative weight	65 Kg (143 lbs)	65 Kg (143 lbs)	75 Kg (165 lbs)
Max pump flow rate	100 l/min (0.3 GPM)	100 l/min (0.3 GPM)	100 l/min (0.3 GPM)
Max drying fan flow rate	40 m³/h	✗	40 m³/h
Max number of dosing pumps for chemicals with flowmeters	2	2	3
Chemical tanks capacity	0.6 l (0.2 US gal)	0.6 l (0.2 US gal)	5 l (1 US gal)
Communication ports	2 pcs USB for PC and FLASH DRIVE; 1 pc RS232	2 pcs USB for PC and FLASH DRIVE; 1 pc RS232	2 pcs USB for PC and FLASH DRIVE; 1 pc RS232
1x Touch control panel	✓	✓	✓
2x Touch control panel	✗	✗	✗
Single manual door with interlock	✓	✓	✓
Pass-through manual door with interlock	✗	✗	✗
Forced air drying	✓	✗	✓
HEPA H14 filter	✓	✗	✓
Cold water connection	✓	✓	✓
Hot water connection	✗	✗	✗
Deionized water connection	●	●	●
Water softener system	●	●	●
Boiler for deionized water	✗	✗	✗
Boiler for hot water	✗	✗	✗
Conductivity probe	●	●	●
Spray arm monitor	●	●	●
Coil for facility steam	✗	✗	✗
Hybrid heating system: electric- steam	✗	✗	✗
Wall drain pump	✗	✗	✗
(E.T.S.) Empty Total System	✗	✗	✗
Wash chamber LED light	●	●	●
Automatic washing trolley recognition	✗	✗	✗
Printer	●	●	●
Standards	EN ISO 15883, MDD, IEC, UL, EMC	EN ISO 15883, MDD, IEC, UL, EMC	EN ISO 15883, MDD, IEC, UL, EMC

✓	Standard
●	On request
✗	Not available

■ External dimensions

AWD655-2 | AWD655-2XE

WxDxH: 595x520x600 mm
(23.4"x20.5"x23.6")

AWD655-2H

WxDxH: 595x520x818 mm
(23.4"x20.5"x32.2")

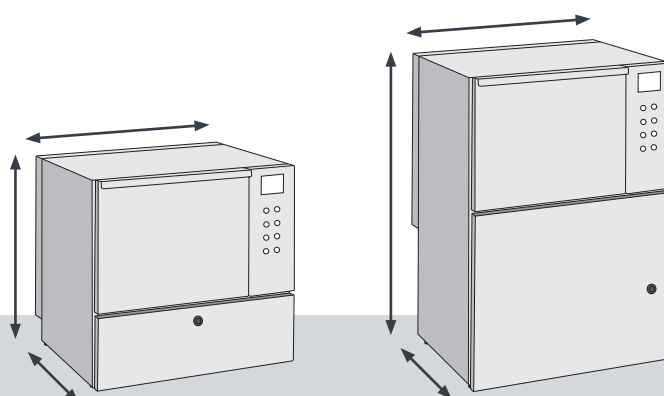

The reference values are based on standard model.

165 LT

AWD655-8 | AWD655-8X AWD655-8XE

Under the counter

Machines equipped with a manual door made in double tempered glass or stainless steel, perfect for dental clinics and ward departments. They are equipped with a system that filter, electrically heat and force, with a powerful blower, the air in the wash chamber and inside the hollow instruments, to obtain an excellent drying result (not available in the model without drying system). A large variety of accessories completes these machines, suitable for washing and disinfecting all types of dental instruments, handpieces and accessories.



AWD655-8 Glass door and with drying



Stainless steel and door with drying **AWD655-8X**

Stainless steel door and without drying **AWD655-8XE**

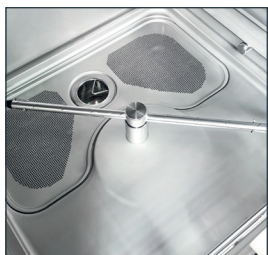

Wash chamber with spray arms

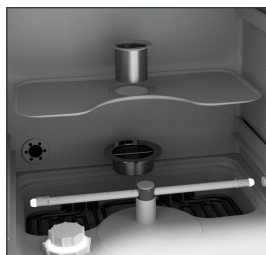

Multi filters in the wash chamber



Stainless steel support for chemical tanks



External printer connected by cable



HEPA H14 filter and prefilter

■ Technical features

	AWD655-8	AWD655-8X	AWD655-8XE
Model code	112002045	112002051	112002048
Wash chamber dimensions (WxDxH)	550x500x600 mm (21.7"x19.7"x23.6")	550x500x600 mm (21.7"x19.7"x23.6")	550x500x600 mm (21.7"x19.7"x23.6")
Wash chamber volume	165 lt (43.6 US gal)	165 lt (43.6 US gal)	165 lt (43.6 US gal)
Wash chamber material	AISI 316L (EN 1.4404)	AISI 316L (EN 1.4404)	AISI 316L (EN 1.4404)
Indicative weight	100 Kg (220 lbs)	100 Kg (220 lbs)	100 Kg (220 lbs)
Max pump flow rate	370 l/min (97.8 GPM)	370 l/min (97.8 GPM)	370 l/min (97.8 GPM)
Max drying fan flow rate	150 m ³ /h	150 m ³ /h	✘
Max number of dosing pumps for chemicals with flowmeters	4	4	4
Chemical tanks capacity	5 l (1 US gal)	5 l (1 US gal)	5 l (1 US gal)
Communication ports	2 pcs USB for PC and FLASH DRIVE; 1 pc RS232	2 pcs USB for PC and FLASH DRIVE; 1 pc RS232	2 pcs USB for PC and FLASH DRIVE; 1 pc RS232
1x Touch control panel	✓	✓	✓
2x Touch control panel	✘	✘	✘
Single manual door with interlock	✓	✓	✓
Pass-through manual door with interlock	✘	✘	✘
Forced air drying	✓	✓	✘
HEPA H14 filter	✓	✓	✓
Cold water connection	✓	✓	✓
Hot water connection	✓	✓	✓
Deionized water connection	●	●	●
Water softener system	●	●	●
Boiler for deionized water	✘	✘	✘
Boiler for hot water	✘	✘	✘
Conductivity probe	●	●	●
Spray arm monitor	●	●	●
Coil for facility steam	✘	✘	✘
Hybrid heating system: electric- steam	✘	✘	✘
Wall drain pump	●	●	●
(E.T.S.) Empty Total System	✘	✘	✘
Wash chamber LED light	●	●	●
Automatic washing trolley recognition	✘	✘	✘
Printer	●	●	●
Standards	EN ISO 15883, MDD, IEC, UL, EMC	EN ISO 15883, MDD, IEC, UL, EMC	EN ISO 15883, MDD, IEC, UL, EMC

✓	Standard
●	On request
✘	Not available

■ External dimensions

AWD655-8 | AWD655-8X
AWD655-8XE

WxDxH: 600x650x845 mm
(23.6"x25.6"x33.3")

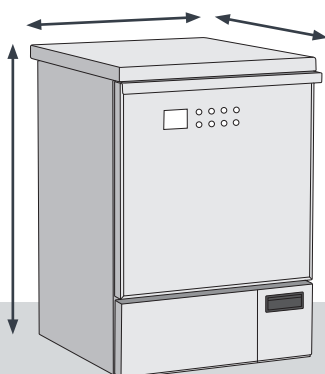

The reference values are based on standard model.

165 LT

AWD655-8L | AWD655-8L-SC AWD655-8XL | AWD655-8XEL

Under the counter

Machines equipped with a side compartment for inserting the detergent tanks and a manual door made in double tempered glass or stainless steel, perfect for dental clinics and ward departments. They are equipped with a system that filter, electrically heat and force, with a powerful blower, the air in the wash chamber and inside the hollow instruments, to obtain an excellent drying result (not available in the model without drying system). A large variety of accessories completes these machines, suitable for washing and disinfecting all types of dental instruments, handpieces and accessories.



AWD655-8L

Glass door and with drying

AWD655-8L-SC

Glass door, with drying and boiler



Stainless steel and door with drying

AWD655-8XL

Stainless steel door and without drying

AWD655-8XEL

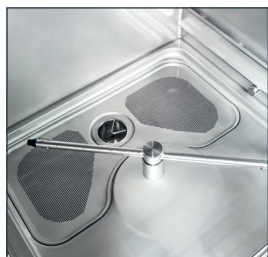

Wash chamber with spray arms

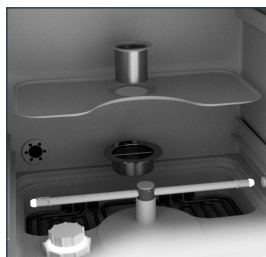

Multi filters in the wash chamber

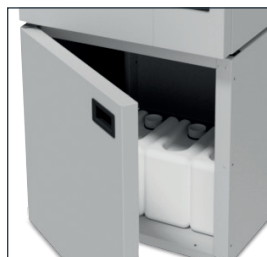

Stainless steel support for chemical tanks



Built-in printer

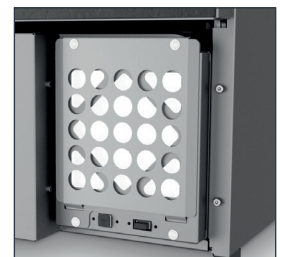

HEPA H14 filter and prefilter

■ Technical features

	AWD655-8L	AWD655-8L-SC	AWD655-8XL	AWD655-8XEL
Model code	112002046	112002047	112002053	112002049
Wash chamber dimensions (WxDxH)	550x500x600 mm (21.7"x19.7"x23.6")	550x500x600 mm (21.7"x19.7"x23.6")	550x500x600 mm (21.7"x19.7"x23.6")	550x500x600 mm (21.7"x19.7"x23.6")
Wash chamber volume	165 lt (43.6 US gal)	165 lt (43.6 US gal)	165 lt (43.6 US gal)	165 lt (43.6 US gal)
Wash chamber material	AISI 316L (EN 1.4404)	AISI 316L (EN 1.4404)	AISI 316L (EN 1.4404)	AISI 316L (EN 1.4404)
Indicative weight	115 Kg (254 lbs)	120 Kg (265 lbs)	115 Kg (254 lbs)	115 Kg (254 lbs)
Max pump flow rate	370 l/min (97.8 GPM)	370 l/min (97.8 GPM)	370 l/min (97.8 GPM)	370 l/min (97.8 GPM)
Max drying fan flow rate	150 m³/h	150 m³/h	150 m³/h	✘
Max number of dosing pumps for chemicals with flowmeters	4	4	4	4
Chemical tanks capacity	5 l (1 US gal)	5 l (1 US gal)	5 l (1 US gal)	5 l (1 US gal)
Communication ports	2 pcs USB for PC and FLASH DRIVE; 1 pc RS232	2 pcs USB for PC and FLASH DRIVE; 1 pc RS232	2 pcs USB for PC and FLASH DRIVE; 1 pc RS232	2 pcs USB for PC and FLASH DRIVE; 1 pc RS232
1x Touch control panel	✓	✓	✓	✓
2x Touch control panel	✘	✘	✘	✘
Single manual door with interlock	✓	✓	✓	✓
Pass-through manual door with interlock	✘	✘	✘	✘
Forced air drying	✓	✓	✓	✘
HEPA H14 filter	✓	✓	✓	✘
Cold water connection	✓	✓	✓	✓
Hot water connection	✓	✓	✓	✓
Deionized water connection	●	●	●	●
Water softener system	●	●	●	●
Boiler for deionized water	✘	✓	✘	✘
Boiler for hot water	✘	✘	✘	✘
Conductivity probe	●	●	●	●
Spray arm monitor	●	●	●	●
Coil for facility steam	✘	✘	✘	✘
Hybrid heating system: electric- steam	✘	✘	✘	✘
Wall drain pump	●	●	●	●
(E.T.S.) Empty Total System	✘	✘	✘	✘
Wash chamber LED light	●	●	●	●
Automatic washing trolley recognition	✘	✘	✘	✘
Printer	●	●	●	●
Standards	EN ISO 15883, MDD, IEC, UL, EMC	EN ISO 15883, MDD, IEC, UL, EMC	EN ISO 15883, MDD, IEC, UL, EMC	EN ISO 15883, MDD, IEC, UL, EMC

■ External dimension

AWD655-8L | AWD655-8L-SC
AWD655-8XL | AWD655-8XEL
 WxDxH: 900x650x845 mm
 (35.4"x25.6"x33.3")

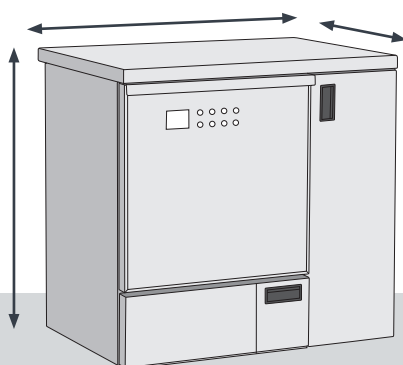

✓	Standard
●	On request
✘	Not available

The reference values are based on standard model.



AWD655-8
WITH 2
INDEPENDENT
LEVELS



THERMALDISINFECTION AND DRYING

Every detail has been optimized and designed to ensure the best performance!

Thermal disinfection is the most recommended and effective method for disinfecting dental devices. Thermal disinfection is required to comply with any legal provision between different countries.

To ensure the best possible results, **the AWD655 line** is also equipped with an efficient hot air drying system that facilitates the total elimination of residual water both inside and outside the dental instruments.

265 LT

AWD655-10 | AWD655-10-SC AWD655-10-2SC

Freestanding column

Machines equipped with a manual door made in double tempered glass, perfect for large dental clinics and ward departments. They are equipped with a system that filter, electrically heat and force, with a powerful blower, the air in the wash chamber and inside the hollow instruments, to obtain an excellent drying result. To ease the loading and unloading of the trolleys, special manual transport trolleys can be used. A large variety of accessories completes these machines, suitable for washing and disinfecting all types of dental instruments, handpieces and accessories.



AWD655-10

Glass door with drying



AWD655-10-SC

Glass door with drying and boiler



AWD655-10-2SC

Glass door with drying and 2 boiler

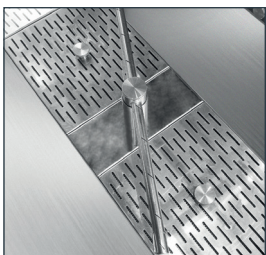

Wash chamber with spray arms



Touch control panel



Chemical tanks



Built-in printer

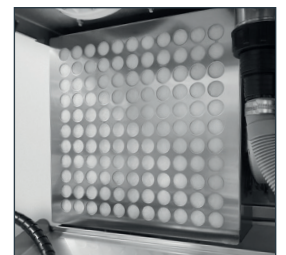

HEPA H14 filter and prefilter

■ Technical features

	AWD655-10	AWD655-10-SC	AWD655-10-2SC
Model code	112002091	112002093	112002104
Wash chamber dimensions (WxDxH)	560x590x800 mm (22"x23"x31.5")	560x590x800 mm (22"x23"x31.5")	560x590x800 mm (22"x23"x31.5")
Wash chamber volume	265 lt (70 US gal)	265 lt (70 US gal)	265 lt (70 US gal)
Wash chamber material	AISI 316L (EN 1.4404)	AISI 316L (EN 1.4404)	AISI 316L (EN 1.4404)
Indicative weight	240 Kg (529 lbs)	255 Kg (562 lbs)	270 Kg (595 lbs)
Max pump flow rate	626 l/min (165.3 GPM)	626 l/min (165.3 GPM)	626 l/min (165.3 GPM)
Max drying fan flow rate	150 m ³ /h	150 m ³ /h	150 m ³ /h
Max number of dosing pumps for chemicals with flowmeters	4	4	4
Chemical tanks capacity	5 l (1 US gal)	5 l (1 US gal)	5 l (1 US gal)
Communication ports	2 pcs USB for PC and FLASH DRIVE; 1 pc RS232	2 pcs USB for PC and FLASH DRIVE; 1 pc RS232	2 pcs USB for PC and FLASH DRIVE; 1 pc RS232
1x Touch control panel	✓	✓	✓
2x Touch control panel	✗	✗	✗
Single manual door with interlock	✓	✓	✓
Pass-through manual door with interlock	✗	✗	✗
Forced air drying	✓	✓	✓
HEPA H14 filter	✓	✓	✓
Cold water connection	✓	✓	✓
Hot water connection	✓	✓	✓
Deionized water connection	●	●	●
Water softener system	●	●	●
Boiler for deionized water	✗	✓	✓
Boiler for hot water	✗	✗	✓
Conductivity probe	●	●	●
Spray arm monitor	●	●	●
Coil for facility steam	●	●	●
Hybrid heating system: electric- steam	●	●	●
Wall drain pump	●	●	●
(E.T.S.) Empty Total System	●	●	●
Wash chamber LED light	●	●	●
Automatic washing trolley recognition	●	●	●
Printer	●	●	●
Standards	EN ISO 15883, MDD, IEC, UL, EMC	EN ISO 15883, MDD, IEC, UL, EMC	EN ISO 15883, MDD, IEC, UL, EMC

■ External dimension

AWD655-10

WxDxH: 650x670x1850 mm
(25.6"x26.4"x72.8")

AWD655-10-SC | AWD655-10-2SC

WxDxH: 650x670x2200 mm
(25.6"x26.4"x86.6")

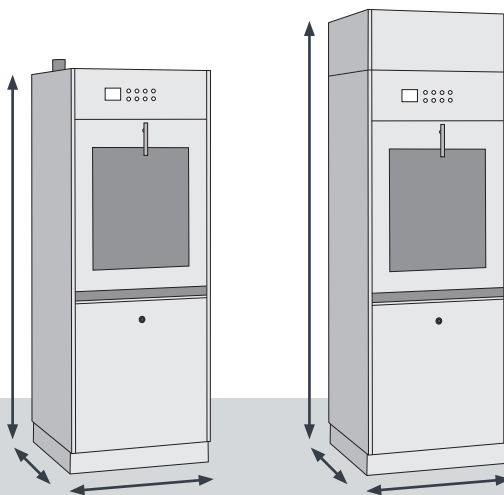

- ✓ Standard
- On request
- ✗ Not available

The reference values are based on standard model.

265 LT

AWD655-10D | AWD655-10D-SC AWD655-10D-2SC

Freestanding column

Machines equipped with pass-through manual door made in double tempered glass. In the machine with two doors, on one side the trolley is loaded with the dirty instruments (dirty room), on the other side the trolley is taken with the cleaned and disinfected instruments (clean room), at the end of the cycle. They are equipped with a system that filter, electrically heat and force, with a powerfull blower, the air in the wash chamber and inside the hollow instruments, to obtain an excellent drying result. To ease the loading and unloading of the trolleys, special manual transport trolleys can be used. A large variety of accessories completes these machines, suitable for washing and disinfecting all types of dental instruments, handpieces and accessories.



AWD655-10D

Pass-through glass door with drying



AWD655-10D-SC

Pass-through glass door with drying and boiler



AWD655-10D-2SC

Pass-through glass door with drying and 2 boiler

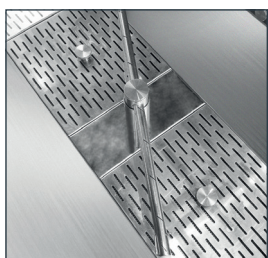

Wash chamber with spray arms



Touch control panel



Chemical tanks



Built-in printer

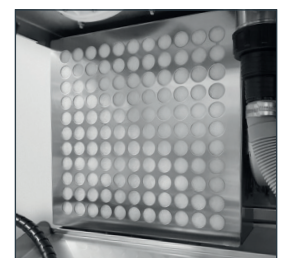

HEPA H14 filter and prefilter

■ Technical features

	AWD655-10D	AWD655-10D-SC	AWD655-10D-2SC
Model code	112002092	112002094	112002111
Wash chamber dimensions (WxDxH)	560x590x800 mm (22"x23"x31.5")	560x590x800 mm (22"x23"x31.5")	560x590x800 mm (22"x23"x31.5")
Wash chamber volume	265 lt (70 US gal)	265 lt (70 US gal)	265 lt (70 US gal)
Wash chamber material	AISI 316L (EN 1.4404)	AISI 316L (EN 1.4404)	AISI 316L (EN 1.4404)
Indicative weight	240 Kg (529 lbs)	255 Kg (562 lbs)	270 Kg (595 lbs)
Max pump flow rate	626 l/min (165.3 GPM)	626 l/min (165.3 GPM)	626 l/min (165.3 GPM)
Max drying fan flow rate	150 m³/h	150 m³/h	150 m³/h
Max number of dosing pumps for chemicals with flowmeters	4	4	4
Chemical tanks capacity	5 l (1 US gal)	5 l (1 US gal)	5 l (1 US gal)
Communication ports	2 pcs USB for PC and FLASH DRIVE; 1 pc RS232	2 pcs USB for PC and FLASH DRIVE; 1 pc RS232	2 pcs USB for PC and FLASH DRIVE; 1 pc RS232
1x Touch control panel	✘	✘	✘
2x Touch control panel	✔	✔	✔
Single manual door with interlock	✘	✘	✘
Pass-through manual door with interlock	✔	✔	✔
Forced air drying	✔	✔	✔
HEPA H14 filter	✔	✔	✔
Cold water connection	✔	✔	✔
Hot water connection	✔	✔	✔
Deionized water connection	●	●	●
Water softener system	●	●	●
Boiler for deionized water	✘	✔	✔
Boiler for hot water	✘	✘	✔
Conductivity probe	●	●	●
Spray arm monitor	●	●	●
Coil for facility steam	●	●	●
Hybrid heating system: electric- steam	●	●	●
Wall drain pump	●	●	●
(E.T.S.) Empty Total System	●	●	●
Wash chamber LED light	●	●	●
Automatic washing trolley recognition	●	●	●
Printer	●	●	●
Standards	EN ISO 15883, MDD, IEC, UL, EMC	EN ISO 15883, MDD, IEC, UL, EMC	EN ISO 15883, MDD, IEC, UL, EMC

■ External dimension

AWD655-10D

WxDxH: 650x700x1850 mm
(25.6"x27.6"x72.8")

AWD655-10D-SC | AWD655-10D-2SC

WxDxH: 650x700x2200 mm
(25.6"x27.6"x86.6")

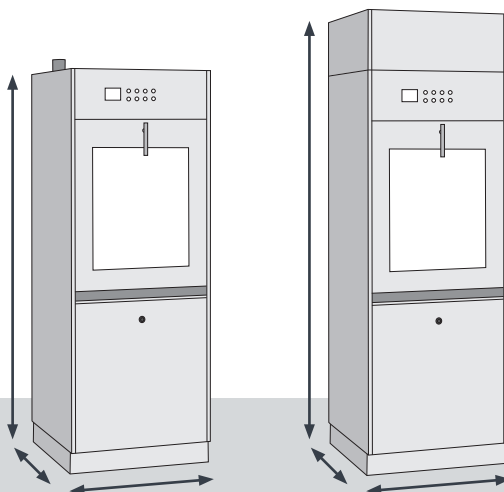

✔	Standard
●	On request
✘	Not available

The reference values are based on standard model.

AWD655 Trolley, Racks and Accessories

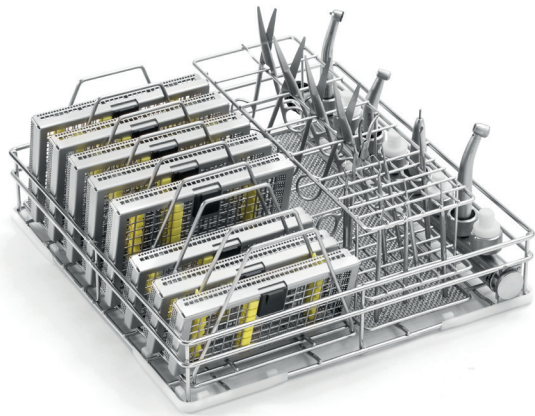

Washing basket with handpieces holder

Washing basket with 8 positions for handpieces. Designed for various inserts and accessories.

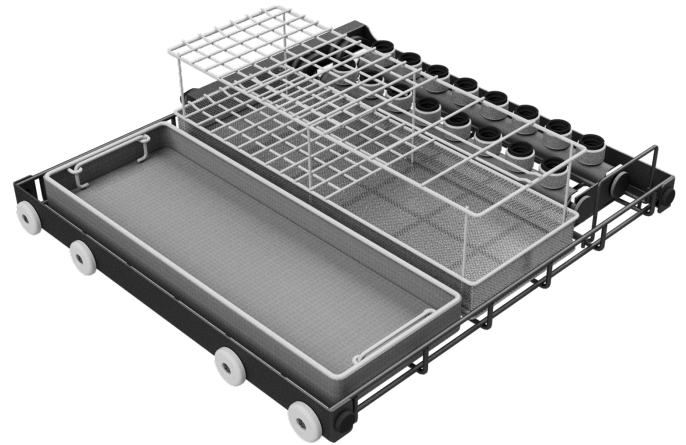

Lower rack with 2 water connections for handpieces holder

Washing rack positioned at the lower level, with 2 water connection for handpieces holder. Active drying of turbines, handpieces and contra angles. Suitable to be configured with various inserts and accessories.

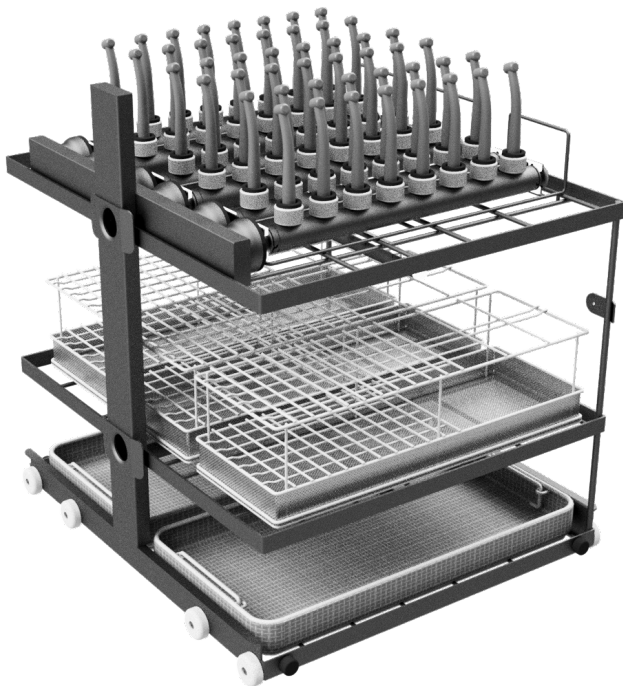

3 level trolley with 6 handpieces holder

3-level washing trolley with spray arms and 6 supports for 8-position handpieces.
Capacity: 48 handpieces.

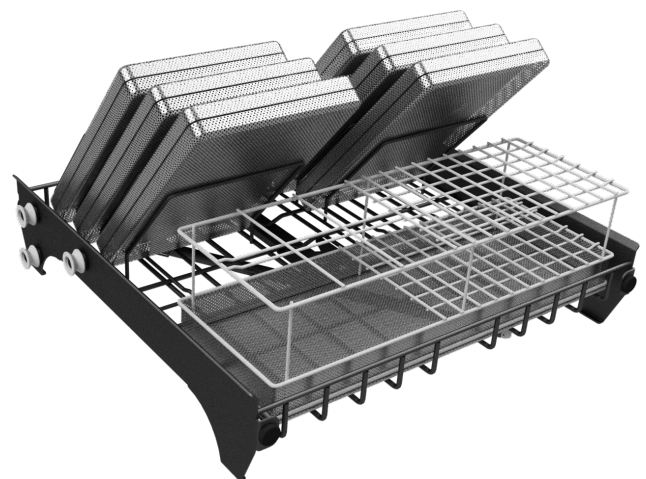

Upper rack with spray arm

Washing rack with spray arm positioned at the upper level, basic version. Suitable to be configured with various inserts and accessories.



Support for hanpieces holder



Support for 8 scaler tips



Nozzle for aspirator tips



Rinsing basket with fixed lid for small accessories

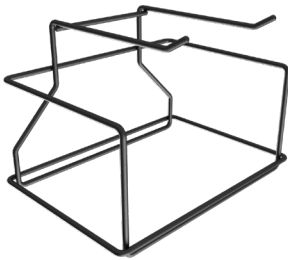

Insert for washing dental impression

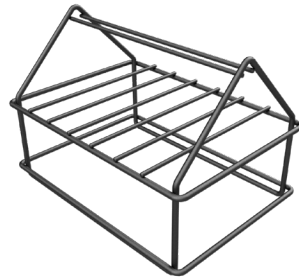

Insert for washing extraction pliers

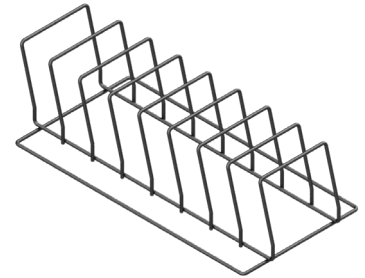

Insert for washing trays or cassettes

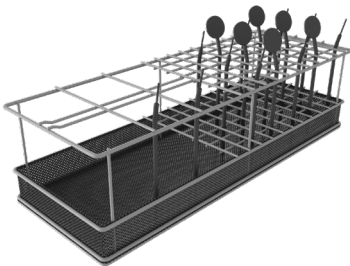

Insert for washing vertical instruments

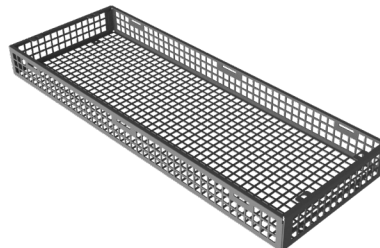

Dental basket

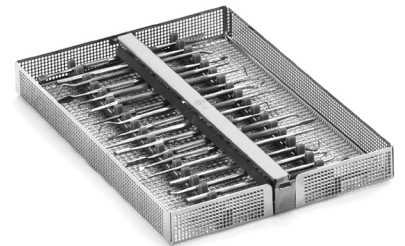

Basket with two silicone supports

MORE TROLLEY, RACKS, INSERTS AND ACCESSORIES AVAILABLE

ACCESSORIES CATALOGUE FOR EVERY MACHINES

Want to know all the trolleys, racks, inserts and accessories?

Contact us to get the accessories catalogue with all the details!

info@at-os.com



HOSPITAL

CSSD

RETIREMENT HOMES

DRYING CABINETS

DENTAL

LABORATORY

VETERINARY

STAINLESS STEEL FURNITURE



AT-OS SRL

Viale del Lavoro, 19- 37030 Colognola ai Colli
Verona- ITALY

Tel (+39) 045 6159411- Fax (+39) 045 6159422

info@at-os.com | www.at-os.com

